



SERVICE DIRECTIVE BULLETIN

SERVICE DIRECTIVE BULLETIN NO. 0111

Revision 1

Page 1 of 5

REVISION 1: Model 280FX was added to the EFFECTIVITY Listing. Weld-On 45 was replaced by Loctite 4212 adhesive.

DATE: June 29, 2011

1. SUBJECT: Tail Rotor Driveshaft and Tach Drive Pulley Guard Inspection
2. MODEL: F-28A, 280, F-28C, 280C, F-28F, 280F, and 280FX
3. EFFECTIVITY: All serial numbers
4. REFERENCE: Enstrom F-28A/F-28C Series Maintenance Manual, Latest Revision
Enstrom 280/280C Series Maintenance Manual, Latest Revision
Enstrom F-28F/280FX Series Maintenance Manual, Latest Revision

5. BACKGROUND:

Enstrom has received reports from the field regarding interference between the tail rotor driveshaft and the rotor tach assembly pulley guard. The observations include witness marks in the epoxy coating of the tail rotor driveshaft and, in some instances, grooves cut into the tail rotor drive shaft. Additionally, contact between the pulley guard and the upper cowling was occurring, as evidenced by abrasions to the epoxy coating on the top of the pulley guard.

This Service Directive Bulletin (SDB) requires a one time inspection of the tail rotor drive shaft.

6. COMPLIANCE:

At or before the next annual inspection, inspect the tail rotor drive shaft for scratches and grooves in accordance with paragraph 6.1.

At the owner's discretion, the rotor tach assembly pulley guard may be modified in accordance with paragraph 6.2 to facilitate maintenance procedures for the tail rotor system and to increase the clearance between the pulley guard and the upper cowling.

June 29, 2011

6.1 TAIL ROTOR DRIVESHAFT INSPECTION

NOTE

Perform all maintenance in accordance with the applicable F-28 or 280 series maintenance manual for the aircraft model, as appropriate.

NOTE

Refer to Figure 1 for the item numbers referenced in the following text.

- A. Access the rotor tach assembly by removing the side cowling (either side) and upper cowling.
- B. Locate the rotor tach assembly pulley guard (Item 11).
- C. Inspect the circumference of the driveshaft where the driveshaft passes through the pulley guard hole. Examine the driveshaft surface for nicks and scratches.
 - 1) Nicks or scratches not deeper than 0.030 inch/0.76 mm may be blended out. Apply corrosion protection after repair.
 - 2) Nicks or scratches in excess of 0.030 inch/0.76 mm are cause for rejection. Replace the driveshaft with a new airworthy part.
 - 3) If either conditions 1) or 2), are present, proceed to Step D.
 - 4) If there is no evidence of nicks, scratches or any type of contact, no additional inspection of the driveshaft is needed.
- D. Inspect the clearance between the pulley guard and the driveshaft. If the driveshaft is not centered through the pulley guard hole:
 - 1) Inspect the driveshaft for straightness and alignment (F-28F/280F Series MM, Reference Paragraph 10-6.H.1 and 10-6.L, respectively).
 - 2) Inspect the pulley guard installation for mount, security, and damage. Replace a damaged pulley guard with a new airworthy part (see Paragraph 6.2 before installing a replacement).
 - 3) If either conditions 1) or 2) are satisfactory, no additional inspection is required.
- E. Proceed to paragraph 6.2 for the optional modifications, otherwise re-install the upper and side cowling.

June 29, 2011

6.2 PULLEY GUARD MODIFICATION

NOTE

The following modifications are optional. Use caution while modifying the pulley guard to avoid damaging the tail rotor driveshaft.

NOTE

Refer to Figures 1 and 2 for the following modification steps.

- A. The modification removes material between the clips of the pulley guard to simplify maintenance operations pertaining to the rotor tach assembly or the tail rotor driveshaft and increases the hole diameter to add clearance between the driveshaft and the pulley guard. This modification may be performed with the rotor tach assembly left intact.
- 1) Remove the pulley guard attachment hardware (Items 12, 13, and 14) and slide guard forward for access. Note the placement and number of washers used for shimming.
 - 2) Using a suitable metal cutting tool, cut out the area of the pulley guard between the clips (refer to Figure 2).
 - 3) Remove the pulley guard by slipping it off the driveshaft via the cutout area. Avoid scratching the driveshaft. It will be necessary to twist the guard to provide additional clearance with the driveshaft.
 - 4) The pulley guard hole may be machined to a maximum 1.125 inch/28.575 mm diameter (refer to Figure 2).
 - 5) Deburr and apply corrosion protection to all newly cut surfaces.
 - 6) Reinstall the pulley guard.
 - 7) Check the pulley guard clearance with the driveshaft and the pulley belts. Adjust the number of shimming washers, if necessary.
- B. If there is evidence of contact between the upper cowling and the pulley guard, install a Nitrile rubber pad, or equivalent, on top of the pulley guard to provide surface abrasion protection and vibration dampening properties. Note: Select either a 1/16 inch/1.58 mm or 1/8 inch/3.17 mm to match the gap distance between the pulley guard and the cowling. A one square inch piece will be adequate.
- 1) Remove contamination from the pulley guard surface with a clean shop rag wetted with an appropriate solvent. Allow to dry.
 - 2) Install the rubber pad with Loctite 4212 adhesive, or equivalent (refer to Figure 2).
- C. Re-install upper and side cowling.

June 29, 2011

7. PARTS: Epoxy Primer, or equivalent; Loctite 4212 Adhesive, or equivalent; Nitrile rubber, or equivalent
8. SPECIAL TOOLS: N/A
9. MAN-HOURS: Inspection – 0.5 hour, Modifications – 1 hour
10. WARRANTY: N/A
11. WEIGHT CHANGE: N/A
12. LOG BOOK ENTRY: As required for maintenance actions
13. REPETITIVE ACTION: N/A

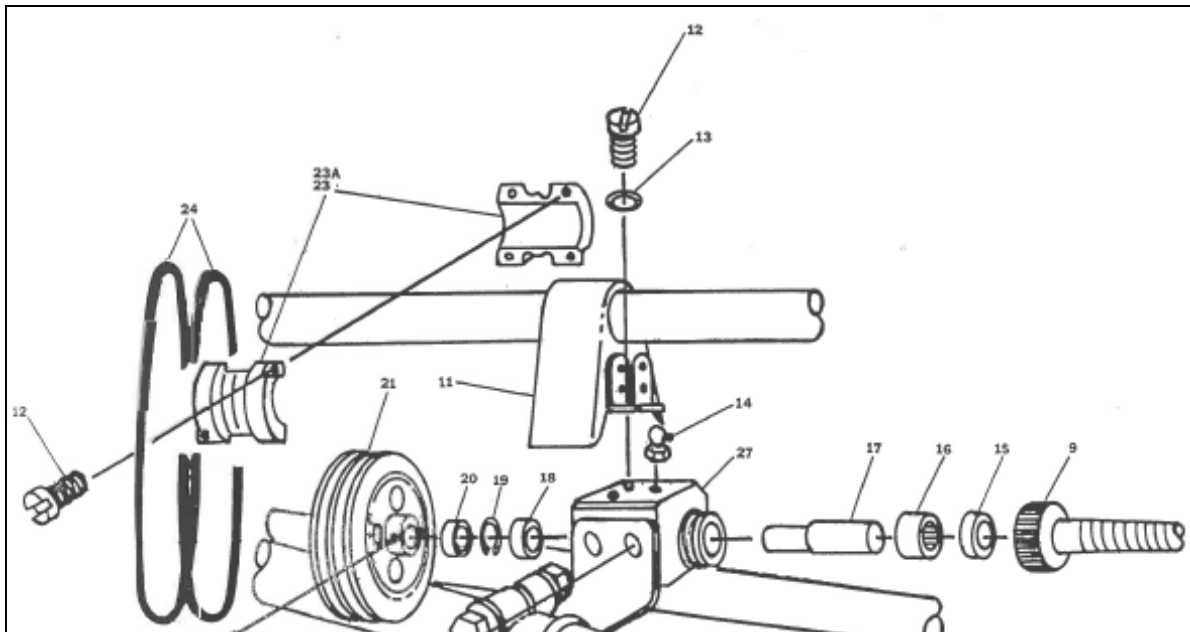

FIGURE 1. ROTOR TACH ASSEMBLY

June 29, 2011

FIGURE 1. ROTOR TACH ASSEMBLY

ITEM NUMBER	PART NUMBER	DESCRIPTION	QTY PER ASSY	MODELS AFFECTED						
				F28A	280	F28C	280C	F28F	280F	280FX
11	28-18031-1	Pulley Guard (Cover)	1	X	X	X	X	X	X	X
12	NK-500-8-8	Screw	2	X	X	X	X	X	X	X
13	AN960-8	Washer	2	X	X	X	X	X	X	X
14	1911-B	Grease Fitting	1	X	X	X	X	X	X	X

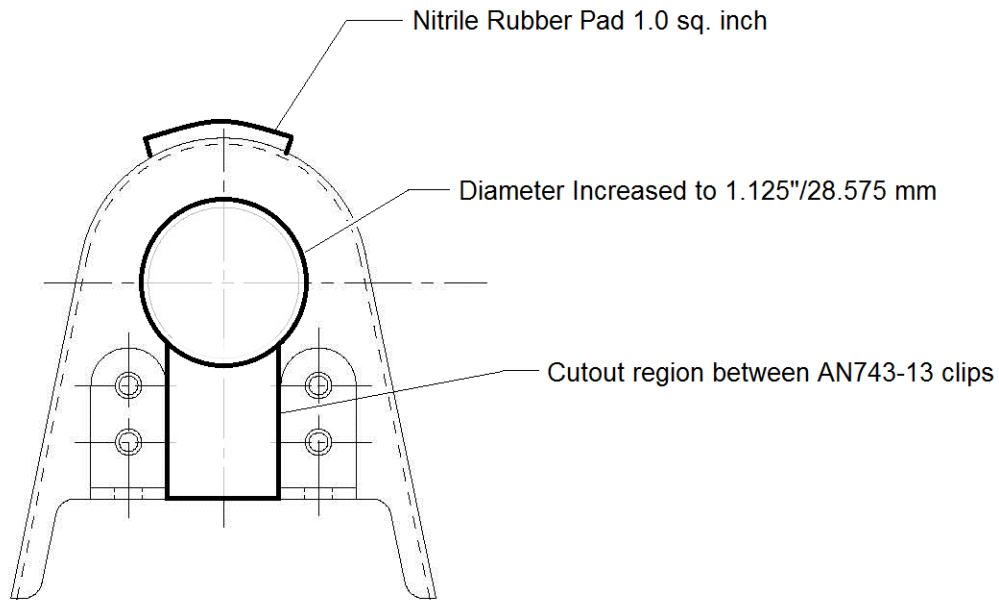

FIGURE 2. PULLEY GUARD OPTIONAL MODIFICATIONS