



SERVICE INFORMATION LETTER

SERVICE INFORMATION LETTER NO. 0090

Date: May 23, 1979

Subject: Fuel Nozzle Air Vent Modification

Models: F-28C, 280C

Effectivity: All "C" Models manufactured prior to 5-29-79

Compliance: At owners earliest convenience or at the next 100 hour inspection

There exists the possibility of failure to the air vent manifold assembly in the area of the small tube attachment, (due to lack of cushion in the grommet where the tube passes through the engine baffle). This manifold is located on either side of the engine and just above the rocker box covers. Reference Figure 1.

In order to reduce the possibility of failure to the nozzle air vent manifold the following corrective procedure is recommended.

1. Loosen clamps that secure rubber hose from fuel nozzle and slide hose from the nozzle vent manifold tube.
2. Remove the nozzle vent manifold assembly left and right by removing screws from clamps at either end of manifold.
3. Remove the old rubber grommet from the engine baffle and enlarge the hole to .56".
4. Install new rubber grommet P/N AN931-3-9 in the enlarged hole.
5. Reinstall the air manifold assemblies and reconnect the nozzle air vent hose from fuel nozzle.

CAUTION: Care must be taken to assure that no foreign particles have entered the air vent system, during this modification.

This grommet may be purchased from Enstrom Customer Service.

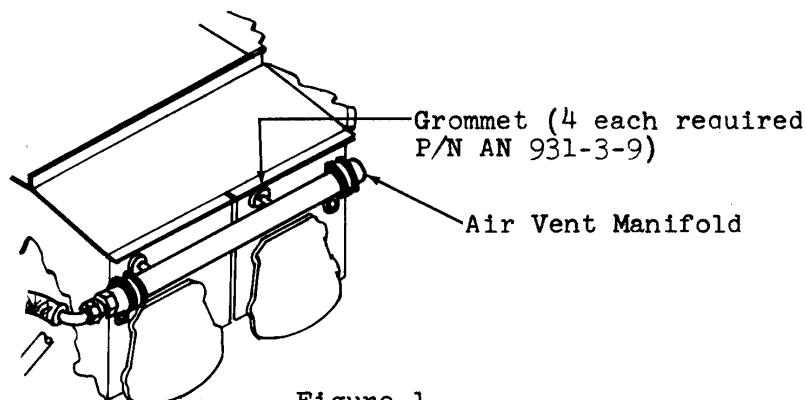

Figure 1